

# ANSYS®

# 12.1

12.1 RELEASE

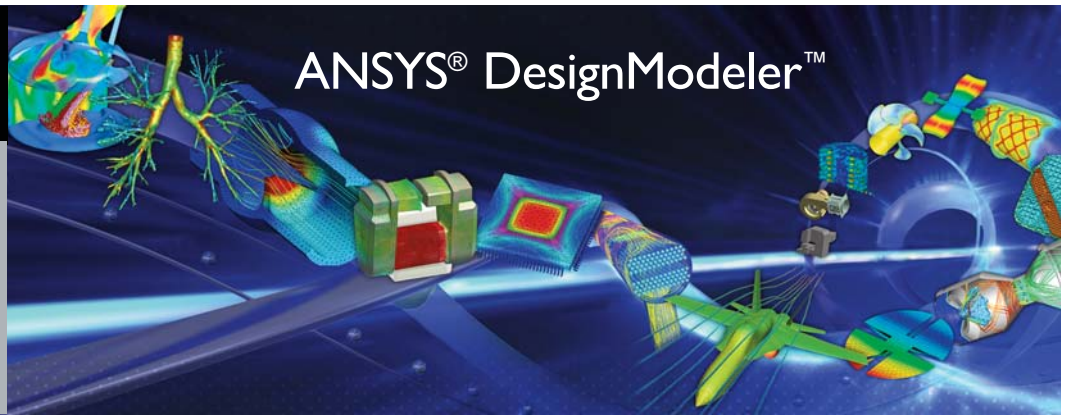

## ANSYS® DesignModeler™

### ANSYS® DesignModeler™ Features

#### 3-D Parametric Modeling

- ▶ Extrude
- ▶ Revolve
- ▶ Sweep
- ▶ Skin/loft
- ▶ Surface
- ▶ Blend
- ▶ Chamfer
- ▶ Welds
- ▶ Share topology

#### Primitive Shapes

- ▶ Sphere
- ▶ Box
- ▶ Parallel piped
- ▶ Cylinder
- ▶ Cone
- ▶ Prism
- ▶ Pyramid
- ▶ Torus
- ▶ Rectangular bend

#### Advanced Features and Tools

- ▶ Merge/slice bodies
- ▶ Surface extraction
- ▶ Surface extension
- ▶ Surface patch
- ▶ Surface flip
- ▶ Join surfaces
- ▶ Freeze/unfreeze
- ▶ Volume enclosure
- ▶ Volume fill
- ▶ Face delete
- ▶ Edge delete
- ▶ Named selection
- ▶ Attribute
- ▶ Symmetry extraction

### Powerful Geometry Modeling for Engineering Simulation

*Unequaled Depth, Unparalleled Breadth*

Creating design models is a core part of the product development process and the first step in the simulation process. These models can be of geometry forms representing actual design details, or they can be approximations of the designs using simplified components like beams and plates. Besides being an essential component of engineering simulation, geometry also links engineering simulation with design and manufacturing, and thereby plays a critical role in Simulation Driven Product Development™.

With direct interfaces to all major computer-aided design (CAD) systems, support of additional readers and translators, and an integrated geometry modeler exclusively focused on analysis, ANSYS offers the most comprehensive geometry handling solutions for engineering simulation in an integrated environment.

The industry-leading ANSYS® Workbench™ computer-aided engineering (CAE) integration environment is CAD-neutral and supports bidirectional, direct, associative interfaces with all major CAD systems. The environment includes a feature-based solid modeler, which can be used to create a parametric geometry from scratch or prepare an existing CAD geometry for analysis. These tools provide a parametric and persistent modeling environment that is ideal for performing design optimization.

#### Automation with the Flexibility to Customize

*Parametric and Persistent*

Geometry modeling in the ANSYS Workbench environment is highly automated and also provides users the flexibility to customize according to the type of analysis or application. The feature-based, parametric ANSYS® DesignModeler™ software can be used to create parametric geometry from scratch or to prepare an existing CAD geometry for analysis. It includes automated options for simplification, cleanup, repair and defeaturing.

Simulation often demands unique modeling capabilities that typical CAD operations do not require. Therefore, these capabilities are either lacking in CAD systems or implemented in a fashion that is not optimum for performing simulation.

ANSYS DesignModeler software provides unique modeling functions for simulation that include parametric geometry creation, concept model creation, CAD geometry modification, automated cleanup and repair, and several custom tools designed for fluid flow, structural and other types of analyses.

## ANSYS DesignModeler Features

- ▶ Mid-surfacing
- ▶ Connect
- ▶ Projection
- ▶ Pattern
- ▶ Boolean
- ▶ Repair tools
- ▶ Analysis tools
- ▶ Body operation

### 3-D Concept Modeling

- ▶ Beams from lines/edges
- ▶ Plates from lines/sketches
- ▶ I I cross-section types
- ▶ Parametric cross sections

### 2-D Sketching

- ▶ Drawing tools
- ▶ Line modifications
- ▶ Dimensions and constraints

### Others

- ▶ Parameter Manager
- ▶ Scripting API

## Parametric Geometry Creation

*Advanced Technology, Process Compression*

The ANSYS DesignModeler product supports a sketch-and-extrude approach to creating parametric geometry. It offers extrude, revolve, sweep, chamfer and other standard geometry creation features to create fully parametric models. In addition, it supports primitives and Boolean operations for creating a new geometry or adding complementary geometry to an existing model. These models can be used with any core simulation product from ANSYS, or with the ANSYS® DesignXplorer™ product for performing design optimization.

## Concept Model Creation

*Beam and Shell Modeling*

Concept models are used in a product development process prior to any detailed CAD geometry being created. These design approximations, along with simulation results, are extremely useful in making fast product decisions early in the design cycle, when product costs can be impacted significantly.

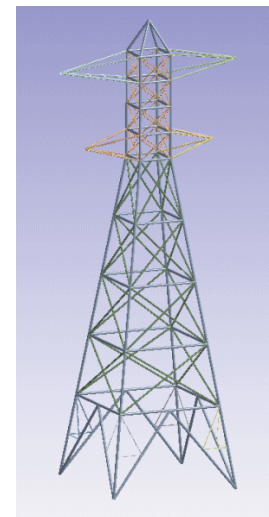
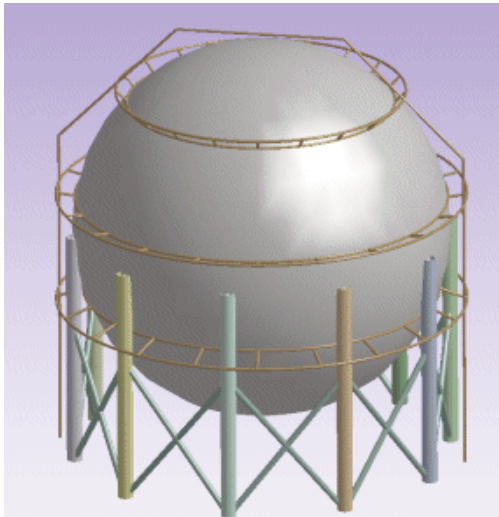

Storage tank and power line tower models using beam modeling tools in ANSYS DesignModeler software

## Preparing Existing Geometry for Analysis

*Advanced Technology, Greater Automation and Process Compression*

CAD models are usually intended to accurately represent the exact intents of the final designs and often lack additional features required for simulation. The ANSYS DesignModeler tool provides these unique simulation features, such as splitting surfaces for applying loads, defining welds or creating regions around models that represent flow volumes for fluid flow analysis.

A CAD model also may contain much more detail than the simulation process requires, or the detail may not be in the right form. ANSYS DesignModeler software enables tasks like deleting CAD features, extracting surfaces from a solid body, suppressing parts, merging multiple bodies into one and grouping bodies to form a part.

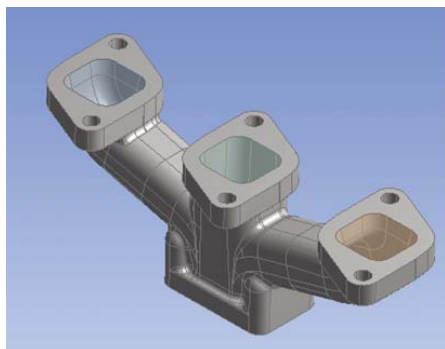

**Solid geometry of a manifold**

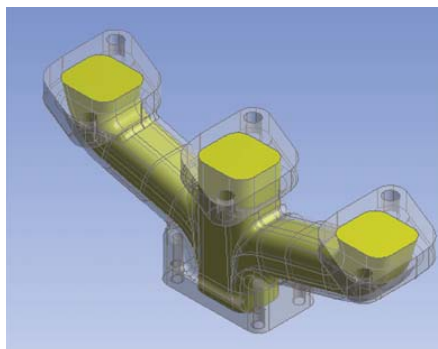

**Flow volume automatically extracted in ANSYS DesignModeler software**

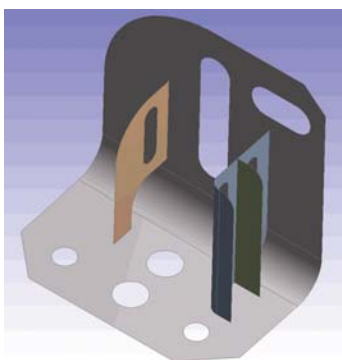

**Solid geometry of a part**

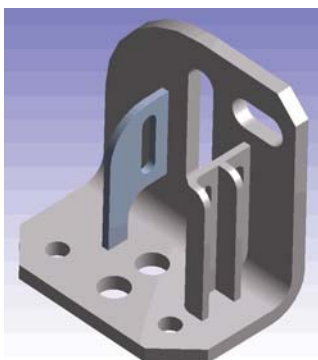

**Surface geometry for the same part extracted in ANSYS DesignModeler software**

ANSYS DesignModeler software also provides several tools for shell/surface modeling. Face and edge merge operations can be used to easily simplify models by eliminating unnecessary features and boundaries, leading to improved meshes and faster solutions. Sew and connect operations can be used to ensure proper connectivity in models with gaps and overlaps.

Similarly, the ability to select and extend groups of surfaces greatly simplifies the process of closing gaps between parts after midsurface extraction. This results in easier modeling of welds, for example. In addition, several features are available for beam modeling, including support of standard cross sections, user-defined offsets, user-defined cross sections and tools for orientation control.

## Automated Cleanup and Repair

### Process Compression

Cleanup and repair of problematic geometries are major bottlenecks in engineering simulation. The cleanup and repair tools in ANSYS DesignModeler software automatically detect and fix typical problems, such as small edges, sliver faces, holes, seams, and faces with sharp angles. This allows geometry models to be prepared for analysis at a fast pace.

As always, analysis settings remain persistent after these operations and are updated automatically in response to changes in geometry.

## Geometry Interfaces

### Bidirectional CAD Connections

- ▶ CATIA® V5
- ▶ UG™ NX™
- ▶ Autodesk® Inventor®
- ▶ Autodesk® MDT
- ▶ CoCreate Modeling™
- ▶ Pro/ENGINEER®
- ▶ SolidWorks®
- ▶ Solid Edge®

### PDM Interface

- ▶ Teamcenter Engineering

### CAD Readers

- ▶ CATIA V4
- ▶ CATIA V5
- ▶ ACIS®
- ▶ IGES
- ▶ Parasolid®
- ▶ STEP
- ▶ STL
- ▶ ANSYS BladeGen
- ▶ Monte Carlo N-Particle

### Geometry Export

- ▶ Parasolid®
- ▶ IGES
- ▶ STEP
- ▶ ANSYS ANF
- ▶ Monte Carlo N-Particle

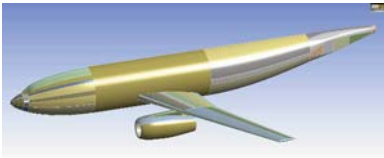

Aircraft model before cleanup

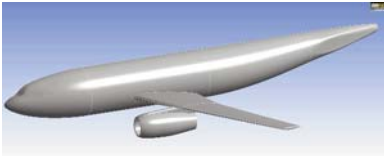

Same aircraft model after cleanup

## The ANSYS Advantage

With the unequalled depth and unparalleled breadth of our engineering simulation solutions, companies are transforming their leading edge design concepts into innovative products and processes that work. Today, 97 of the top 100 industrial companies on the “FORTUNE Global 500” invest in engineering simulation as a key strategy to win in a globally competitive environment. They choose ANSYS as their simulation partner, deploying the world’s most comprehensive multiphysics solutions to solve their complex engineering challenges. The engineered scalability of our solutions delivers the flexibility customers need, within an architecture that is adaptable to the processes and design systems of their choice. No wonder the world’s most successful companies turn to ANSYS — with a track record of almost 40 years as the industry leader — for the best in engineering simulation